



## ELECTRICITY GENERATION USING SMALL WIND TURBINES AT YOUR HOME OR FARM

S. Clarke

The wind is a clean and plentiful source of energy. The Canadian Wind Energy Association (CanWEA) believes that wind energy could potentially supply up to 20% of Canada's electricity requirements.

Wind turbines used to generate electricity come in a wide variety of sizes. Large wind turbines, which are usually installed in clusters called windfarms, can generate large amounts of electricity. Large wind turbines may even produce hundreds of megawatts (MW) of electricity — enough to power hundreds of homes. Small wind turbines, (see *Figure 1*), which are generally defined as producing no more than 100 kW of electricity, are designed to be installed at homes, farms and small businesses either as a source of backup electricity, or to offset use of utility power and reduce electricity bills. Very small wind turbines (20 – 500 watt units) are used to charge batteries for sailboats and other recreational uses.



**FIGURE 1.** Wind turbine. (Source: Ontario Wind Smith)

A small wind energy system could prove to be a practical and economical source of electricity for your home or farm if some or all of the following are true:

- Your property has a good wind resource.
- Your property is at least one acre in size.
- Your local zoning ordinances allow wind turbines.
- Your electricity bills tend to be high.
- Your property does not have easy access to utility lines, i.e. off electrical power grid.
- You are comfortable with making long-term investments.
- Turbine is 250–300 m away from your neighbour's house (closer for small turbines ie.1 kW).

### WIND AVAILABILITY

Whether constructing a wind turbine is economically viable at your home or farm depends most strongly on the quality of your wind resource. Generally, average annual wind speeds of at least 4.0–4.5 m/s (14.4–16.2 km/h; 9.0–10.2 mph) are needed for a small wind turbine to produce enough electricity to be cost-effective. A very useful resource for evaluating a site for its wind energy potential is a wind resource potential map. (See wind maps *Figures 13 & 14* end of the Factsheet.)

It may be useful to check wind speed measurements that have been recorded at a local weather station. It is important to consider that siting factors at these weather stations, such as nearby trees and buildings, might

influence any wind speed measurements. Also, keep in mind that the equipment at these stations is often located close to the ground, and that weather stations located at airports are usually sheltered from the wind. This means that wind speed measurements recorded at these stations might under represent the wind potential at your site.

For the most precise evaluation of the wind speed at your site, you need to purchase a wind resource evaluation system. While wind resource evaluation systems can be expensive, if your property is hilly and has unusual terrain features then it might be worth obtaining one.

The most important component of a wind resource evaluation system is an *anemometer*. Anemometers are typically designed with cups mounted on short arms that are connected to a rotating vertical shaft.

The anemometer rotates in the wind and generates a signal that is proportional to the wind speed. If you do purchase an anemometer, you will also need to purchase something to record the readings made by the anemometer, and a tower or tripod to mount the whole system on.

For as little as \$500 you might be able to purchase a wind totalizer, which is a very simple type of wind resource evaluation system where the anemometer is linked to an odometer. The odometer is similar to those found in cars. After a period of time, the number recorded on the odometer, which represents the total “distance” the anemometer has turned, can be divided by the time passed since the odometer was last checked in order to determine the average wind speed over a period of time at a location.

More expensive wind resource evaluation systems are available. On many systems, a data logger continuously records wind speeds measured by the anemometer, and the data can be downloaded to a computer. These types of wind measurement systems provide a more accurate assessment of the wind resource at a location, but are much more expensive. For example, a system of this type, where the anemometer and data logger would be mounted on a 10 ft tripod, cost \$5,000 in 2002.

No matter what measurement system you install, for a small wind turbine a minimum of one year of data should be recorded and compared with another source of wind data. It is very important that the measurement equipment is set high enough to avoid turbulence created by trees, buildings or other obstructions. Readings would be most useful if they have been taken at *hub height*, or the elevation at the top of the tower where the wind turbine is going to be installed (Figure 2).

If there is a small wind turbine system in your area, you may be able to obtain useful information from its owners about the annual electrical output of the system and, possibly, wind speed data. Such information could be extremely valuable as an alternative to installing a wind resource evaluation system.

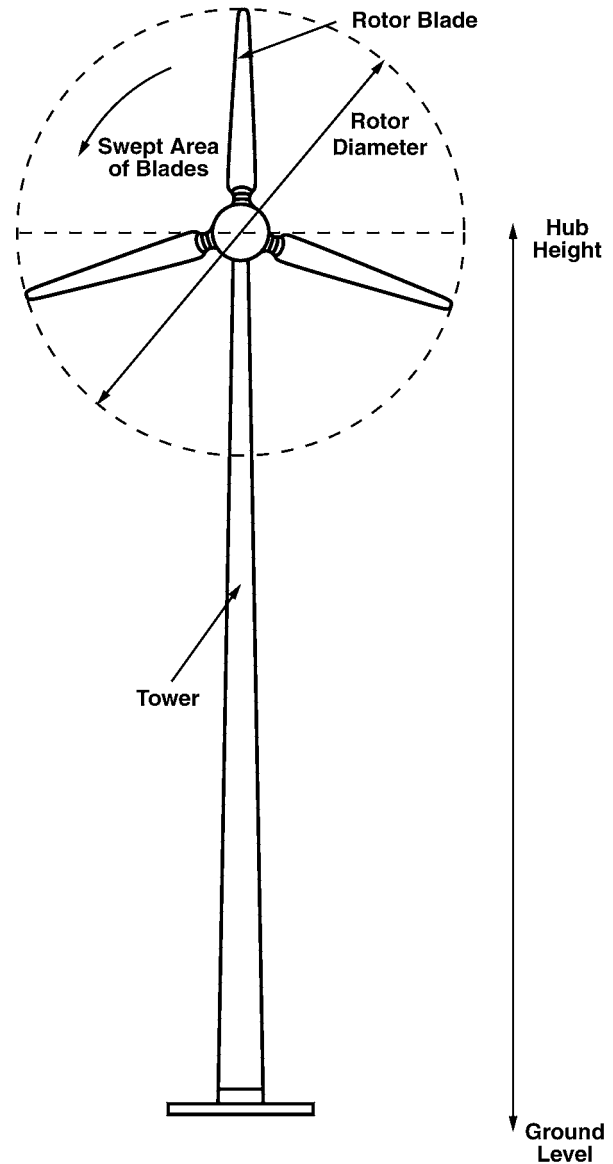

**FIGURE 2:** Wind turbine schematic. (Modified image from Natural Resources Canada)

### **PICKING THE BEST LOCATION FOR A WIND TURBINE**

Where you choose to build your wind turbine is important. Remember that if nearby houses, tree lines and silos obstruct the full force of the wind from your wind turbine, you will not be able to generate as much power.

Also keep the following in mind:

- Wind speeds are always higher at the top of a hill, on a shoreline, and in places clear of trees and other structures.
- Remember that trees grow over the years; wind turbine towers do not.
- Inform neighbours of your plans to avoid conflict later on.
- Be courteous. Keep the turbine as far away from neighbours as possible. 250–300 m away is typical.
- Check with the local government for any other bylaws and regulations about zoning.

Wind speeds tend to be higher on the top of a ridge or hill, and for that reason it is a good idea to locate wind turbines at hilly locations. Just remember to keep your turbine away from high turbulence. Neighbours must also be taken into consideration when picking a spot to build your turbine. The farther your wind turbine site is from neighbouring houses, the better.

Do not expect your wind turbine to generate the same amount of power all the time. The wind speed at a single location may vary considerably, and this can have a significant impact on the power production from a wind turbine (Figure 3). Even if the wind speed varies by only 10%, the power production from a wind turbine can vary by up to 25%!

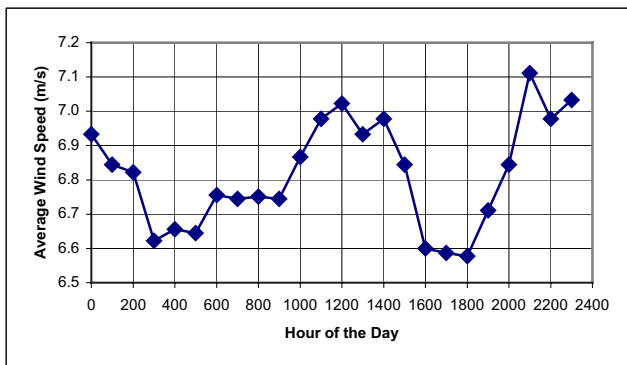
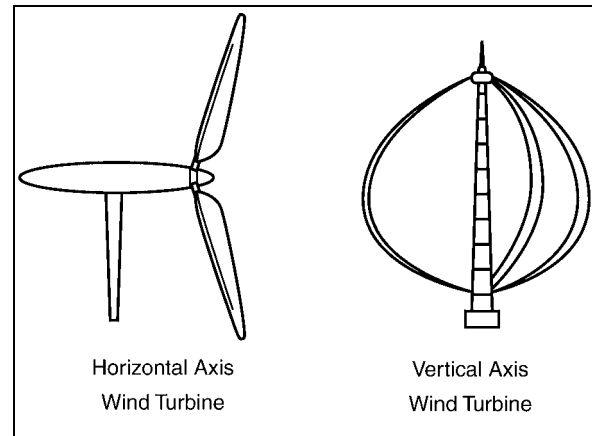

**FIGURE 3:** Example of wind speed distribution by hour of the day. Values shown are monthly averages of measurements made by anemometers. (Source: US Department of Energy)

### TYPES OF WIND TURBINES

There are two basic types of wind turbines: *horizontal axis wind turbines* and *vertical axis wind turbines* (Figure 4). Horizontal axis turbines (more common) need to be aimed directly at the wind. Because of this, they come

with a *tailvane* that will continuously point them in the direction of the wind. Vertical axis turbines work whatever direction the wind is blowing, but require a lot more ground space to support their guy wires than horizontal axis wind turbines.



**FIGURE 4.** Source: Ontario Ministry of Energy

### COMPONENTS OF WIND ENERGY SYSTEMS

The basic components of a typical wind energy system are shown on Figure 5.

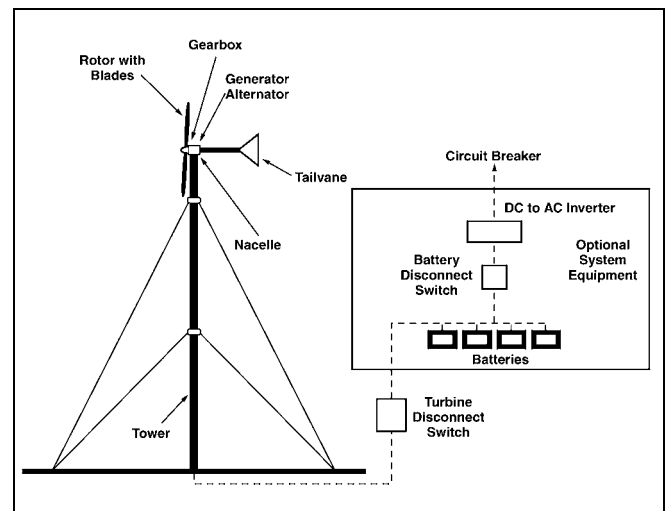

**FIGURE 5.** Components of a wind energy system. (Source: Natural Resources Canada)

These basic components include:

- A *rotor*, consisting of blades with aerodynamic surfaces. When the wind blows over the blades, the rotor turns, causing the *generator* or *alternator* in the turbine to rotate and produce electricity.
- A *gearbox*, which matches the rotor speed to that of the generator/alternator. The smallest turbines (under 10 kW) usually do not require a gearbox.

- An enclosure, or *nacelle*, which protects the gearbox, generator and other components of the turbine from the elements.
- A *tailvane* or *yaw system*, which aligns the turbine with the wind.

If you plan on building a horizontal axis wind turbine, you will need a *tower* on which to mount the turbine (vertical axis turbines are usually built on the ground).

Several types of towers are available:

- *Guyed lattice towers*, where the tower is permanently supported by guy wires. These towers tend to be the least expensive, but take up a lot of space on a yard. A radio broadcast tower is a good example of a guyed lattice tower.
- *Guyed tilt-up towers*, which can be raised and lowered for easy maintenance and repair.
- *Self-supporting towers*, which do not have guy wires. These towers tend to be the heaviest and most expensive, but because they do not require guy wires, they do not take up as much space on a yard.

An important factor in how much power your wind turbine will produce is the height of its tower. The power available in the wind is proportional to the cube of its speed. This means that if wind speed doubles, the power available to the wind generator increases by a factor of 8 ( $2 \times 2 \times 2 = 8$ ) (Figure 6). Since wind speed increases with height (Figure 7), increases to the tower height can mean enormous increases in the amount of electricity generated by a wind turbine.

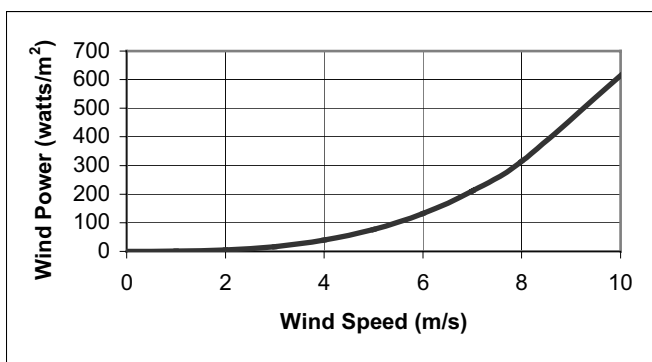

**FIGURE 6.** Relationship between wind speed and wind power.

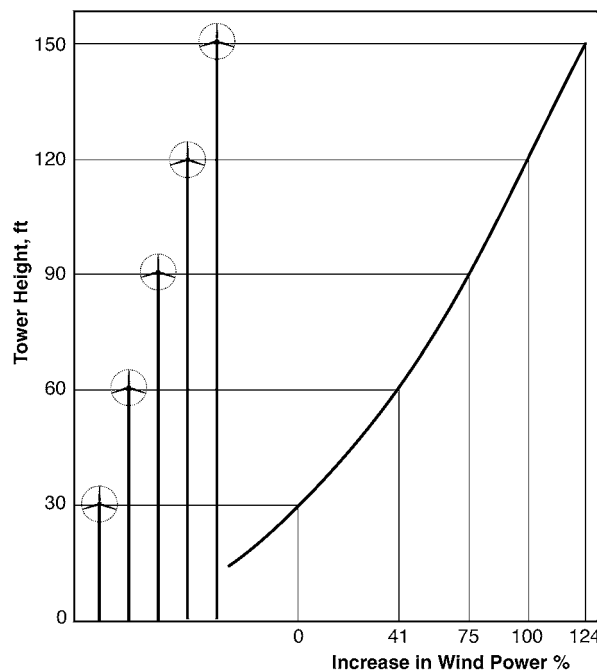

**FIGURE 7.** Wind speeds increase with height. (Source: United States Department of Energy)

It has been recommended that towers be 24–37 m (80–120 ft) high. Installing a wind turbine on a tower that is too short is like installing a solar panel in a shady area. At a minimum, mount a wind turbine high enough on a tower that the tips of the rotor blades remain at least 9 m (30 ft) above any obstacle within 90 m (300 ft).

Make sure to check local bylaws about height restrictions for wind turbine towers. Use a tower approved by the wind turbine manufacturer otherwise the warranty on the turbine may become invalid. Also ensure the tower is connected to an underground metal object to ground the tower in case of a lightning strike.

You need a *disconnect switch* that can electrically isolate the wind turbine from the rest of the wind energy system. An automatic disconnect switch is necessary to prevent damage to the rest of the system in case of an electrical malfunction or a lightning strike. It also allows maintenance and system modifications to be safely made to the turbine.

There are other system components you may choose or need to purchase. You may need *batteries* to store excess energy generated by the wind turbine. Because energy is stored in batteries as DC power, you may need an *inverter* to convert power from the batteries to the AC power required to run electrical appliances in your home.

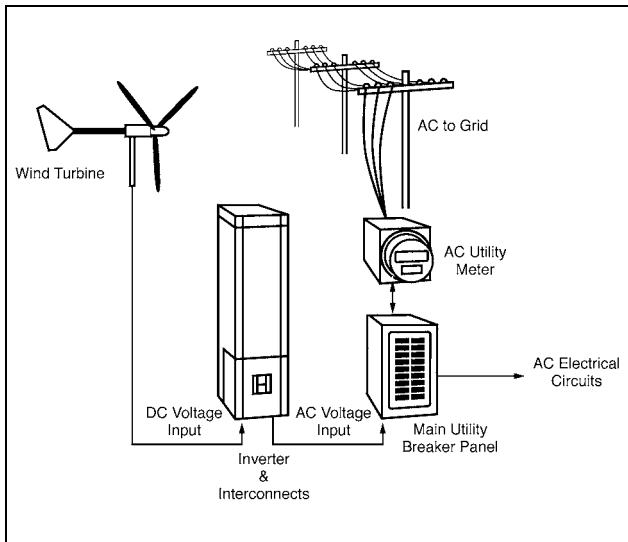

**FIGURE 8.** Diagram of a grid-tied wind electric system. (Source: Phantom Electron Corp.)

If your home or farm is connected to the power grid (Figure 8), on windier days you may be able to “sell” excess power generated by your wind turbine to your utility. Then, at other times when your turbine cannot generate all the power you need, you would buy power from the grid. This concept is called “net metering”, or “net billing”. **Net metering is currently unavailable in most parts of Ontario, but may be available fall 2003. Contact your local utility or Hydro One.**

Even if net metering is unavailable, you might be able to reduce your power bills by using the electricity you generate using a grid-connected wind turbine. If you do this, then you would not have to buy as much electricity from your utility.

If you do connect your wind turbine to the grid, your utility will require a *transfer switch* between the wind turbine and the utility line as well as a *two-way meter* to keep track of the energy you have stored in and taken from the power grid. It is very important that your wind generator meets certain standards and that it does not pose a risk to your utility’s personnel or equipment. It is also important that the quality of power coming from your turbine adequately matches the electrical characteristics in your utility’s power grid.

**HOW MUCH WILL IT COST ME TO PURCHASE A WIND TURBINE?**

It costs \$2,000–\$8,000/per kilowatt to purchase a small wind turbine. However, the wind turbine costs represent only 12%–48% of the total cost of a small wind electric system. You also need to pay for other components of your wind energy system, such as inverters and batteries, as well as sales tax, installation charges and labour.

Keep in mind that the costs of wind power, unlike other sources of electrical power, are almost entirely due to the cost of purchasing and installing the system. Once the turbine has been installed, there is no fuel costs associated with its operation; you will only need to pay for maintenance of your wind turbine.

The cost of the energy produced by small (<10 kW) wind turbines over their lifetimes has been estimated to vary from \$0.07/kWh, for a low cost turbine constructed in a windy area, to \$0.96/kWh, for a high cost turbine constructed in a low wind area (Figure 9).

**Economic Estimates for Small Wind Turbines**

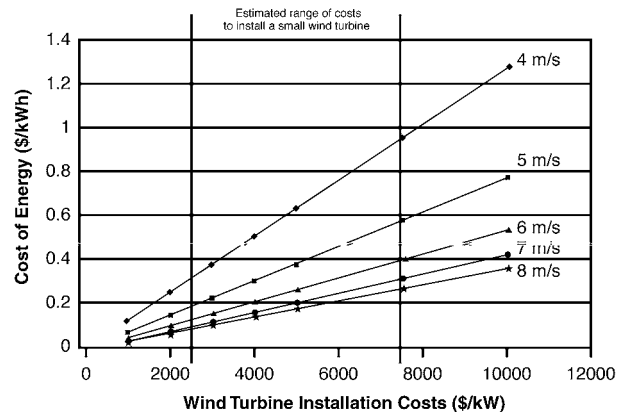

**FIGURE 9:** Estimated cost for electricity produced by small wind turbines (10 kW). (Source: Data by Carl Brothers, Atlantic Wind Test Site)

The performance of a wind turbine is normally described by manufacturers using a performance curve of power output versus wind speed, called a *power curve* (Figure 10).

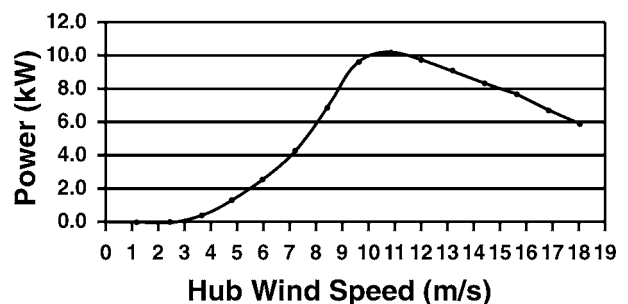

**FIGURE 10.** Examples of a power curve for a small wind turbine rated at 10 kW. (Source: Atlantic Orient Corporation)

One problem with wind turbine ratings is that there is no industry standard for a consistent wind speed at which to measure the output from wind turbines.

Instead, manufacturers choose which wind speed to use for their wind turbine output ratings. Take, for example, the "Wind-o-matic" and the "Mighty-wind", both rated at 1,000 watts. The Wind-o-matic was rated at 5 m/s winds, while the Mighty-wind was rated at 10 m/s. Because the power in the wind is proportional to the cube of its speed (see *Figure 6*), a 1,000-watt turbine rated at 10 m/s will only produce 1/8 of that power at 5 m/s. So, at a wind speed of 5 m/s, the Wind-o-matic will produce 1,000 watts, while the Mighty-wind will only produce 125 watts!

Rather than comparing the rated outputs advertised for different turbines, compare the swept area of the turbines (see *Figure 11*). Since the electrical output of a wind generator is largely a function of its swept area, the larger the swept area of a rotor, the more electricity the wind generator produces. Doubling the area on the solar panels that is exposed to the sun can double the electrical energy generated by solar panels. With wind turbines, swept area works much the same way.

If you do not know the swept areas, you can still make reasonable comparisons between wind turbines by comparing the rotor diameters of the turbines. A modest increase in the rotor diameter will lead to significant increases in both the swept area of a turbine and the amount of electricity that the turbine can generate (*Figure 11*). *Please note that the values for power production shown on Figure 11 are theoretical values, and only intended for illustrative purposes. The actual power production from a wind turbine will be influenced by many other factors, such as: the efficiency that the wind turbine is able to extract energy from the wind; the elevation at which the turbine is located; and other design characteristics of the wind turbine.*

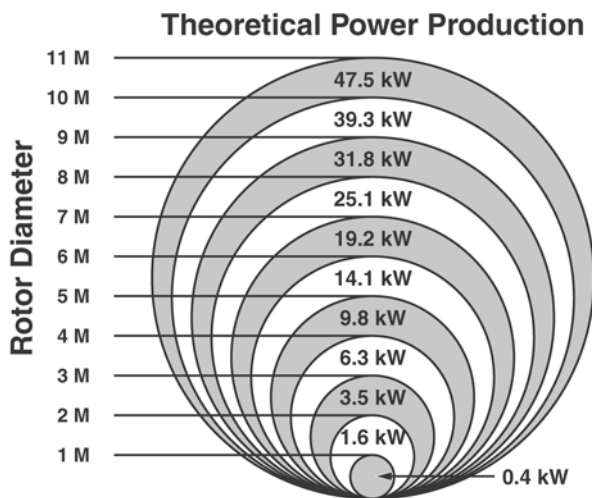

**FIGURE 11.** Theoretical power production for small wind turbines when the wind speed is 10 m/s.

## CHOOSING AN APPROPRIATE WIND TURBINE SIZE

To determine the appropriate size of wind turbine to use, review your monthly electricity consumption in kilowatt-hours (kWh). To do this look at your electricity bills for the last year, add the kilowatt-hours you consumed, and divide by 12. Then compare this total to estimates of the power production for different wind turbines, a figure available from a wind turbine dealer.

To get a preliminary estimate of the performance of a particular wind turbine, use the formula below:

$$AEO = 1.64 D^2 V^3$$

Where:

AEO = Annual energy output, kWh/year

D = rotor diameter, meters

V = Annual average wind speed, m/s

By making your home or farm more energy efficient and reducing the size of your peak demand electrical loads, you can reduce the size of wind turbine you'll need, thereby decreasing the purchase cost.

## BEING NEIGHBOURLY

Many people feel strongly about the need to preserve the landscape, views, history, and peace and quiet of their neighbourhoods. Make sure you discuss your plans to build a wind turbine with your neighbours. Understand your neighbours' natural fear of the unknown and be prepared to respond to their concerns.

Some of the concerns raised about wind turbines are not true. Wind turbines are not, as many people believe, dangerous to birds. A sliding glass door is more dangerous to birds than a small wind turbine. Wind turbines also have a very low potential to interfere with radio and television reception. All modern turbines, large and small, have blades made of fiberglass or wood. These materials are transparent to electromagnetic waves such as radio and television.

## WIND TURBINE NOISE

Your neighbours' concerns relating to wind turbine noise are important. No matter the size of the wind turbine, the potential for turbine noise to bother other people always exists. Even if a wind turbine does not emit enough sound to violate any noise regulations, the noise it produces may still be objectionable to other people. Before building a wind turbine, familiarize yourself with the types of noise your wind turbine could make:

- *Aerodynamic noises* may be made by the flow of air over and past the blades of the turbine. Such noises

tend to increase with the speed of the rotor. For blade noise, lower blade tip speed results in lower noise levels. Of particular concern is the interaction of wind turbine blades with atmospheric turbulence, which results in a characteristic “whooshing” sound.

- *Mechanical noises* may also be produced by components of a wind turbine. Normal wear and tear, poor component designs or lack of preventative maintenance may all be factors affecting the amount of mechanical noise produced.

### HOW LOUD MIGHT A WIND TURBINE BE?

At a distance of 250 m, a typical wind turbine produces a *sound pressure level* of about 45 dB(A) (decibels). As Figure 12 shows, this sound level is below the background noise level produced in a home or office. Most small wind turbines, in fact, make less noise than a residential air conditioner.

#### Small wind turbines

The blades rotate at an average range of 175–500 revolutions per minute with some as high as 1150 rpm. Large turbine blades rotate in the range of at 50–15 rpm at constant speed, although an increasing number of machines operate at a variable speed.

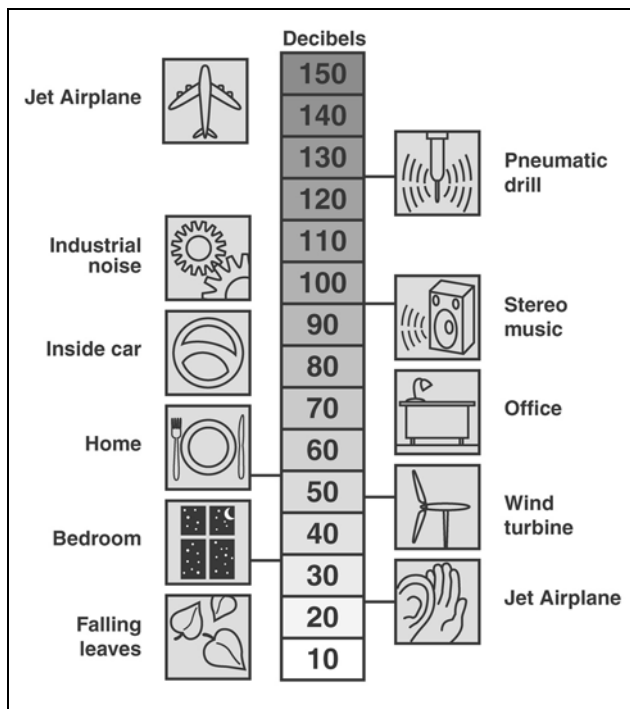

**FIGURE 12.** Comparison of decibel levels from a hypothetical wind turbine (from 250 m away) with other sources of noise. (Source: American Wind Energy Association)

### MAINTENANCE

A wind turbine requires periodic maintenance such as oiling and greasing, and regular safety inspections. Check bolts and electrical connections annually; tighten if necessary. Once a year check wind turbines for corrosion and the guy wires supporting the tower for proper tension.

If the turbine blades are wood, paint to protect from the elements. Apply a durable leading edge tape to protect the blades from abrasion due to dust and insects in the air. If the paint cracks or the leading edge tape tears away, the exposed wood will quickly erode. Moisture penetrating into the wood causes the rotor become unbalanced, stressing the wind generator. Inspect wooden blades annually, and do any repairs immediately.

After 10 years, blades and bearings may need to be completely replaced. With proper installation and maintenance, your turbine can last 20–30 years or longer. Proper maintenance will also minimize the amount of mechanical noise produced by your wind turbine.

### SAFETY CONCERNS

All wind turbines have a maximum wind speed, called the survival speed, at which they will not operate above. When winds over this maximum occur, they have an internal brake and lock to prevent them from going faster than this survival speed.

For turbines operating in cold winter conditions, be prepared to de-ice as required, and store batteries in an insulated place.

Mounting turbines on rooftops is generally not recommended unless a wind turbine is very small (1 kW of rated output or less). Wind turbines tend to vibrate and transmit the vibration to the structure on which they are mounted. As a result, turbines mounted on a rooftop could lead to both noise and structural problems with the building and rooftop.

### INFORMATION HAS BEEN CONDENSED FROM THE FOLLOWING SOURCES

- Ontario Ministry of the Environment: [www.ene.gov.on.ca/envision/electricity.elect.htm](http://www.ene.gov.on.ca/envision/electricity.elect.htm)
- American Wind Energy Association: [www.awea.org/faq/rsdntqa.html](http://www.awea.org/faq/rsdntqa.html)
- *Buying a Small Wind Electric System: Small Wind Electric Systems: A California Consumer's Guide*

- *Small Wind Electric Systems: A U.S. Consumer's Guide.* U.S. Department of Energy
- *Choosing a Home-Sized Wind Generator.* Apples & Oranges 2002: Home Power # 90  
August/September 2002: Mick Sgrillo
- *Small Wind Turbines: Buyer Beware.* Carl Brothers, Atlantic Wind Test Site, North Cape, PEI, COB 2B0
- *Wind Energy System's A Buyer's Guide.* CANMET. Canada Centre for Mineral and Energy Technology Department of Natural Resources Canada, 580 rue Booth, Ottawa, On K1A 0E4
- *Wind Resources Assessment In Southwestern Ontario.* CANMET, Short Report. Canada Centre for Mineral and Energy Technology.
- *Stand-Alone WindEnergy Systems. A Buyer's Guide.* Natural Resources Canada,
- *Field Verification Project for Small Wind Turbines, April 2002.* Quarterly Report. Produced for the U.S. Department of Energy 1000 Independence Avenue, S.W. Washington, D.C. 20585. National Renewable Energy Laboratory {NREL}  
<http://www.nrel.gov/wind/>
- *Distributed Applications Growing for Small Wind Turbines Choosing a Wind Power System.* Ontario Ministry of Energy

## RESOURCES

### Internet Resource Information for Renewable Wind Energy

Atlantic Wind Test Site	<a href="http://www.awts.pe.ca">www.awts.pe.ca</a>
Canadian Wind Energy Association	<a href="http://www.canwea.ca">www.canwea.ca</a>
Canadian Association for Renewable Energies	<a href="http://www.renewables.ca">www.renewables.ca</a>
Canadian Renewable Energy Network	<a href="http://www.canren.gc.ca">www.canren.gc.ca</a>
Renewable Energy and Sustainable Energy Systems in Canada	<a href="http://www.newenergy.org/welcome.html">www.newenergy.org/welcome.html</a>
Energy Centre of Wisconsin (U.S.)	<a href="http://www.ecw.org">www.ecw.org</a>
Home Power Magazine (U.S.)	<a href="http://www.homepower.com">www.homepower.com</a>
The National Wind Technology Center	<a href="http://www.nrel.gov/wind/">www.nrel.gov/wind/</a>
Wind Energy Weekly (U.S.)	<a href="http://www.awea.org/wew/">www.awea.org/wew/</a>

### Manufacturers/Distributors of Small Wind Generators

Atlantic Orient Corporation	AOC	<a href="http://www.aocwind.net">www.aocwind.net</a>
Bergey Windpower	Bergey	<a href="http://www.bergey.com">www.bergey.com</a>
Marlec Engineering	Rutland	<a href="http://www.marlec.co.uk">www.marlec.co.uk</a>
Proven Engineering	Proven	<a href="http://www.almac.co.uk/proven/">www.almac.co.uk/proven/</a>
Southwest Windpower	Whisper AIR-X	<a href="http://www.windenergy.com">www.windenergy.com</a>
Windstream Power Systems		<a href="http://www.windstreampower.com">www.windstreampower.com</a>
Wind Turbine Industries	Jacobs® Windstream	<a href="http://www.windturbine.net/">http://www.windturbine.net/</a>
Vergnet Canada	Vergnet	<a href="http://www.vergnet.fr">www.vergnet.fr</a>

### Contact Information

Can WindPower	<a href="http://canwindpower.com">http://canwindpower.com</a>
Canadian Renewable Energy Corporation	<a href="http://www.crec.ca/wind.htm">http://www.crec.ca/wind.htm</a>

### Wind Resource Evaluation Systems

Campbell Scientific Canada Corp. 11564 - 149 St Edmonton Alberta T5M 1W7 Phone -(705) 454-2505	NRG Systems 110 Commerce St Hinesburg, VT 05461 USA Phone: (802) 482-2255 Web: <a href="http://www.nrgsystems.com">www.nrgsystems.com</a> Email: <a href="mailto:sales@nrgsystems.com">sales@nrgsystems.com</a>
---	--

This Factsheet was written by **Steve Clarke**, P. Eng., Engineer, Rural Environment, Kemptville, OMAF, and reviewed by **Hugh Fraser**, Engineer, Horticultural Crop Structures & Equipment, Vineland, OMAF. Special thanks to **Ryan MacKenzie** for his contributions.

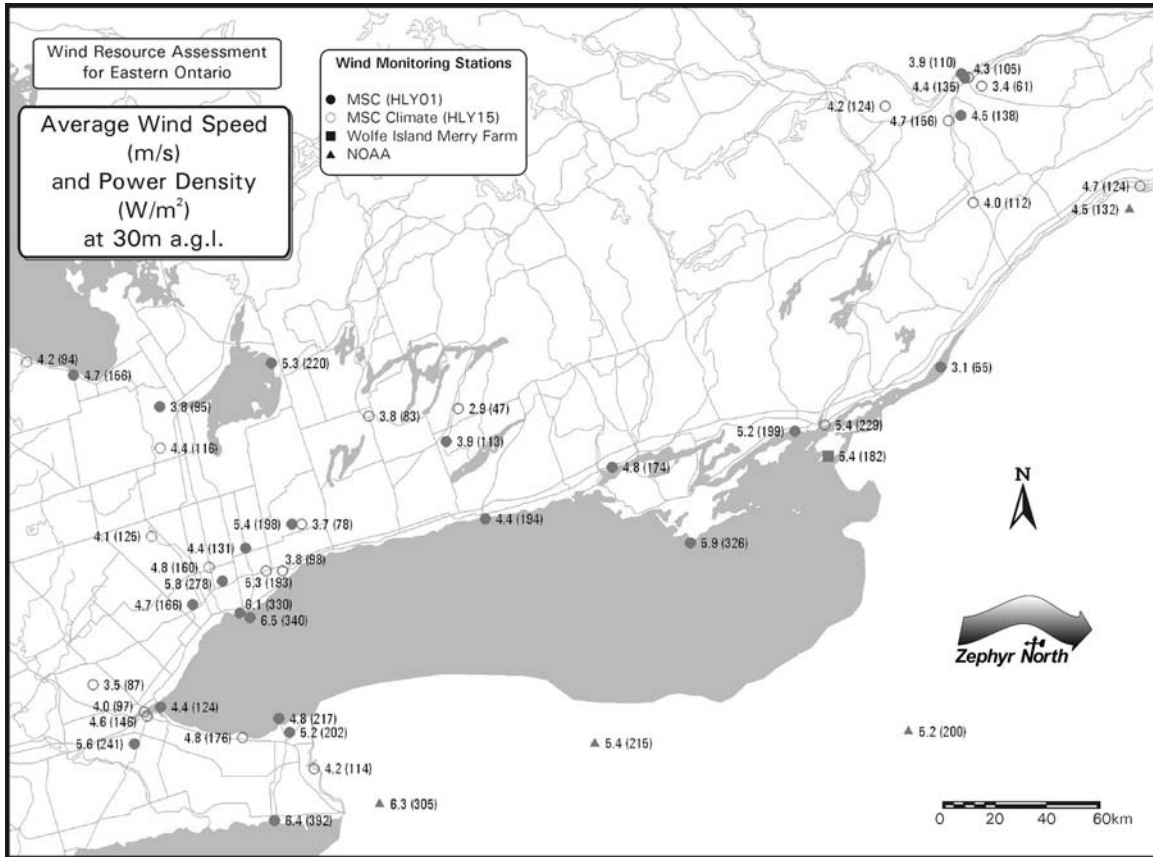

**FIGURE 13.** Wind Map for Eastern Ontario. (a.g.l. = above ground level) (Source: Natural Resources Canada/Zephyr, North Corporation)

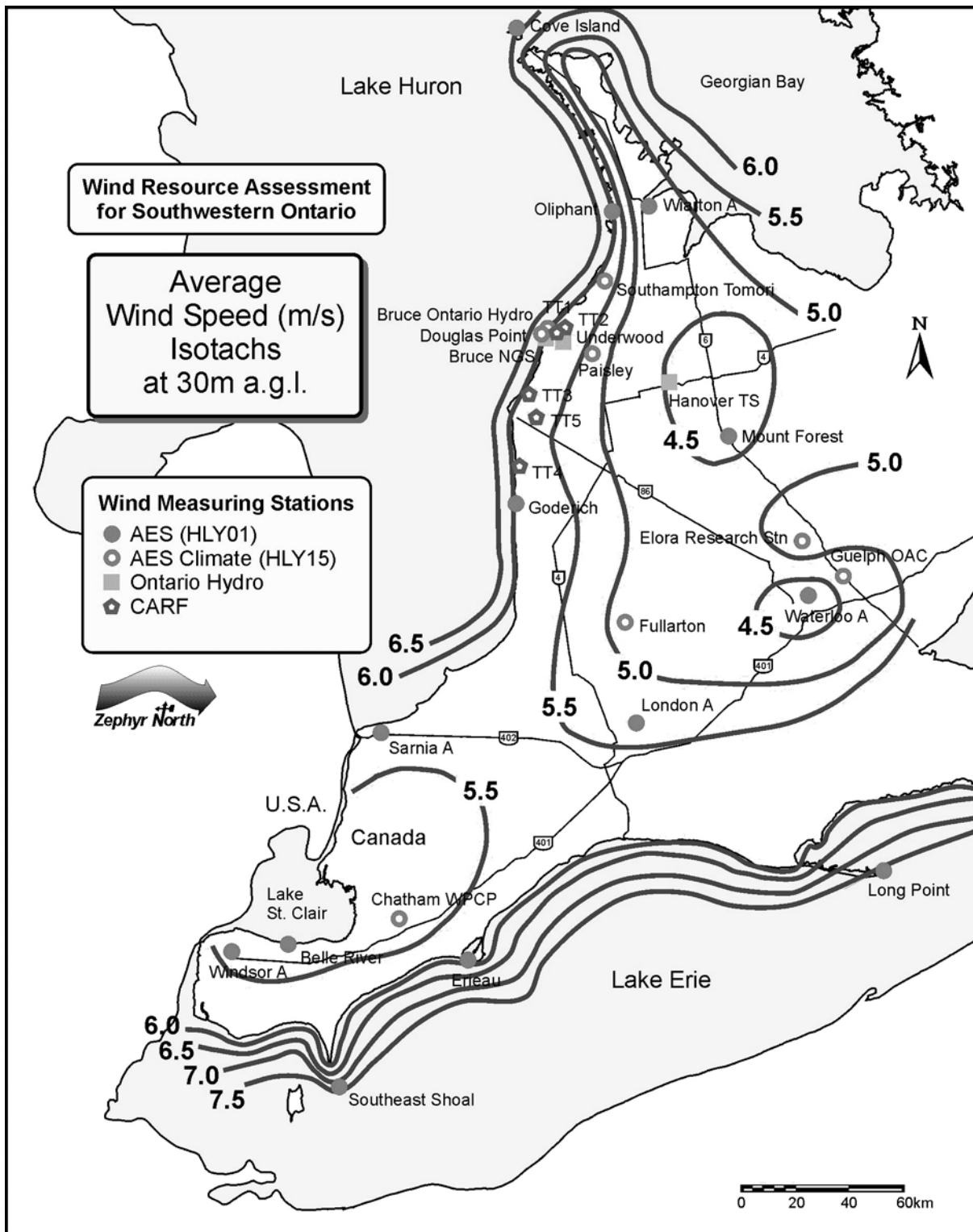

FIGURE 14. Wind Map for Southwestern Ontario. (Source: Natural Resources Canada/Zephyr, North Corporation)

**FOR YOUR NOTES**

---

Agricultural Information Contact Centre  
1-877-424-1300  
*ag.info@omaf.gov.on.ca*

**[www.omaf.gov.on.ca](http://www.omaf.gov.on.ca)**

---

**POD**  
ISSN 1198-712X  
Également disponible en français  
(commande n° 02-048)

