



Ontario

Ministry of Agriculture,
Food and Rural Affairs

HARVESTING AND STORING LARGE BALE HAYLAGE

S. Clarke P.Eng

(Replaces OMAFRA Factsheet "Harvesting and Storing Big Bale Haylage," Order No. 88-094)

Large bale haylage, with its potential for high-quality feed, very low waste and moderate costs, has been gaining popularity with Ontario's livestock farmers.

Advantages of Haylage

- Uses existing haymaking equipment
- Lower harvest losses
- Less weather dependent than dry hay systems
- Higher quality feed

Disadvantages of Haylage

- Heavier bales may require larger handling equipment
- Increase in annual costs
- Potentially higher storage losses

Dry matter losses in the field, largely the result of shattering and loss of protein-rich leaves are cut substantially by harvesting a wetter material. For example, harvesting haylage at 55% moisture as opposed to dry hay at 18% can cut field and storage losses approximately in half. (Figure 1)

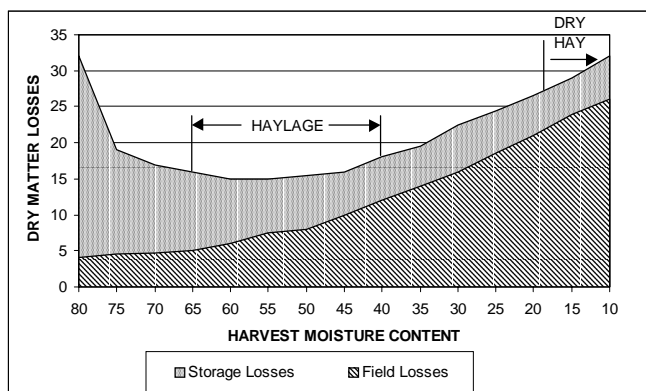

FIGURE 1: Field and storage losses

Use only top quality forage for large bale haylage. Poor quality, rain-damaged material, or a forage crop that is mature and lacks the sugars necessary for good fermentation will not produce quality feed and will have a reduced storage life.

HARVESTING

Wilt the crop to 50%–60% moisture. At this moisture level, fermentation is more favourable in terms of sugar content than in wetter material and seepage losses are minimized. The amount of forage mowed must be coordinated closely with drying conditions, baling and covering. If the crop gets much drier than 40% moisture let it dry for hay. Ensiling material with too little moisture increases the risk of heating due to increased oxygen penetration, which will lead to mold growth and a marked depression in the protein digestibility.

Proper machinery for making and transporting heavier, high moisture bales is necessary. Do not attempt to work with very large bales. A 4 ft x 4 ft (diameter x length) bale at 55% moisture will weigh 1200 pounds whereas a 4 ft x 5 ft bale at 55% moisture content will weigh 1500 pounds.

It is important to move the bales to storage and enclose them in plastic as soon as possible after baling. Regardless of whether the haylage is stored individually, in tubes or in stacks, sealing all air out is critical. During the respiration stage of the ensiling process the oxygen that is trapped in storage is rapidly consumed by aerobic bacteria. Anaerobic bacteria, which survive in the absence of oxygen, begin to grow and multiply in the fermentation stage and convert the plant sugars into organic acids — mainly lactic and acetic.

With production of acids, the pH of the silage is reduced from an original level of 7.0 to a final ideal pH of 4–5. Typical large bale haylage has a pH of 4.5–5.5. Fermentation ceases when bacteria growth is stopped by the accumulation of acids. The haylage will then remain at a stable pH with no bacterial growth and can be preserved for a long time, providing there is no exposure to air.

Using silage additives to aid fermentation is generally unnecessary, however they may be beneficial in situations where, forage material is drier than recommended, cold weather cut, or crop has been rained on.

ROUND BALE VS SQUARE BALE HAYLAGE

The reasons for using either round or square bale haylage systems vary from farm to farm. They include existing baling and handling equipment, storage facilities, amount of haylage made and the availability of local custom operators are all factors to take into consideration.

Advantages of Round Bale Haylage

- More widely available, less expensive baling and wrapping equipment
- Variable diameter bales (hard core balers) can be made smaller to reduce weight.

Advantages of Square Bale Haylage

- Safer to handle than round bales
- Higher stacking density (reduced storage space and cost)

STORAGE OPTIONS

A. Individual Bales

Wrapping big bales with "stretch" plastic has proven to be an effective method of storage. This plastic film is basically a low-density polyethylene with a tacky additive to help it create a tight seal.

Individual wrapping is generally performed by machinery that rotates the bale on a turntable. The farmer starts the wrapping procedure by tucking the end of the plastic film under the twine, and when wrapping is complete, cuts the wrapped bale free. Wrapping machines (*Figure 2*) are available to handle round or square bales of various sizes. Some equipment will handle both types of bales however they are more costly.

Best results are expected when sound bales — that is, bales that will not "squat" — are wrapped as tightly as possible. It is recommended that bales be wrapped with at least 4 layers of film for short storage and at least 6 layers of film for late spring to early summer storage.



FIGURE 2. Wrapped square and round bales

When handling individually wrapped bales, a grapple loader attachment is ideal (*Figure 3*). The use of a spear will break the seal and spoil the bale if not immediately fed. If stacking individually wrapped round bales, it is best to place bales two high on the flat end where there is more plastic.

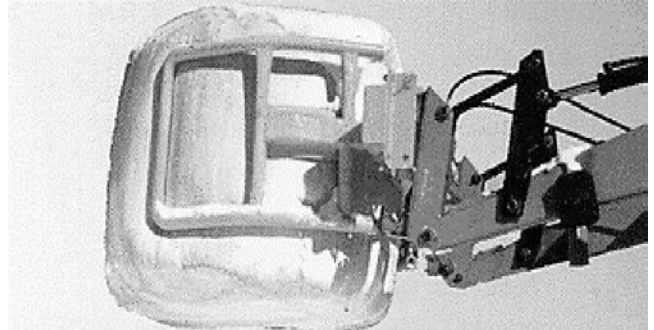

FIGURE 3. Individually wrapped round bale and handling loader attachment

The biggest advantage offered by individually stored haylage systems appears to be its potential to minimize spoilage. Losses for well-wrapped quality haylage stored at the proper moisture content (60%) have been estimated at 5% of dry matter. For tight, well-wrapped bales, a hole in the plastic will mean only localized mould and spoilage rather than the widespread spoilage that develops when loose-fitting plastic covers are punctured. Another advantage to individually wrapped bales over multi-bale systems is the ability to market off-farm as it is very difficult to move a multi-bale unit.

An alternative to using stretch film is the manual placement of bales into individual bags. If dealing with a large number of bales, the bagging will work best with three people. Check all bags for holes immediately after bagging and then periodically afterwards. Patching can be effective if done with minimal delay. Haylage bags come in various sizes and thicknesses. The lighter bags are 4 mil polyethylene and have a one-year life expectancy, while 5 and 5.5 mil bags will often provide 2 seasons of use if the farmer is willing to patch any holes before re-using.

B. Multi-Bale

Flex tubes (*Figure 4*) of polyethylene and tube filling machines have been developed to decrease the cost, labour and time required bagging individual bales. There is also a multi-bale system (*Figure 5*) that uses the same stretch film as individually wrapped bales. It is estimated that multi-bale systems use up to 40% less plastic over individual wrapping and will therefore lower cost. There are now multi-bale systems that can be used to store big square bale haylage as well as round bale haylage.



FIGURE 4. Multi-bale flex tube machine



FIGURE 5. Multi-bale stretch wrap

The main tubing machine used is the hydraulic powered unit. The tube of plastic is placed on the drum of the machine, but the tubing procedure requires one person operating the hydraulics of the bagger while another brings bales to the machine with a loader. There are different bagging machines of this style, which work with either loose-fitting bags or tight flex (stretch) tubes. With a tighter fitting flex tube, both plastic cost and potential for mass spoilage is reduced.

Multi-bale systems that use stretch film involve the placement of a bale onto the drum of the machine, which is then wrapped with the film. The greatest advantage to this system over a flex tube is that the length of each line of bales is variable and can be adjusted to fit individual operation feed out times and yard space.

When using a multi-bale system to store big square bales, consider experimenting with different arrangements of bales (*Figure 6*). If more haylage can be stored per foot of length, overall cost of storage is reduced. Different bale arrangements work best with various wrapping and tube machines. Try for a square face configuration rather than a rectangular arrangement.

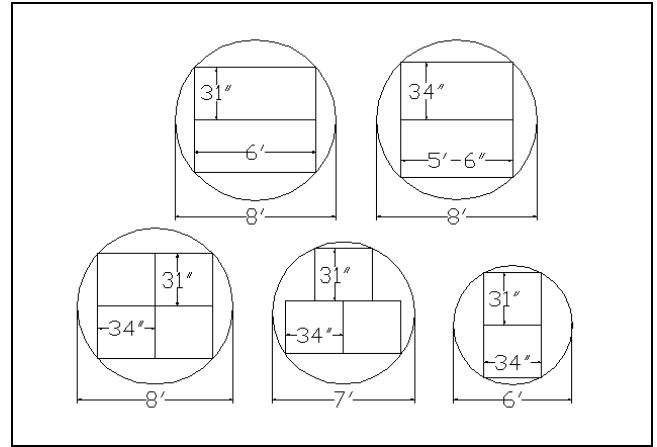

FIGURE 6. Possible multi-bale arrangements for a 31"x 34"x 5 1/2-8' square bales

C. Stacks

Covering and sealing them with a double layer of 6-mil polyethylene can preserve stacks of big bales. This method works well for both round and big square bales. As shown in *Figure 8* and *9*, the outer layer provides the seal, while the inner layer protects it from stem punctures - especially where twine or rope tie-downs are placed. Sand is used to seal the edges of the outer layer, and substantial tie-downs are required to minimize wind buffeting.

Do not use construction grade polyethylene since a big percentage of it is made from a variety of reclaimed plastics, and thus it is an inferior product with variable thickness. On the other hand, silage films — though costing 20% more — are made from pure resins and exhibit vastly superior physical properties (stretch, puncture, and fatigue). In quality silage films a uniform thickness is maintained.

The amount of air initially trapped under the plastic is not critical, since the respiration process quickly uses up oxygen. However, any subsequent hole in the plastic will allow oxygen to enter freely and cause extensive spoilage. As with the other options, steps should be taken to minimize rodent problems and periodic checking of the cover should be practiced.

Some farmers have chosen to place loose haylage in the voids between bales and between bales and the plastic cover. The benefit gained here is that the free movement of air through the stack may be lessened if the stack's seal is broken.



FIGURE 7. An opened stack of square bale haylage

Once a stack is opened (*Figure 7*), deterioration of the haylage commences and continues at a rate that varies with air temperature. Eventually, mould becomes visible on the face of the bales and gradually will penetrate the bales. Plan your stack size so that once opened; it will be entirely fed out: within 1 week in summer; within 2 weeks in spring and fall; and within 4 weeks in winter.

If stacks are kept small (21–35 round bales or 20–40 square bales), placing the plastic will be easier, and problems with ice and snow during winter feed-out will be minimized.

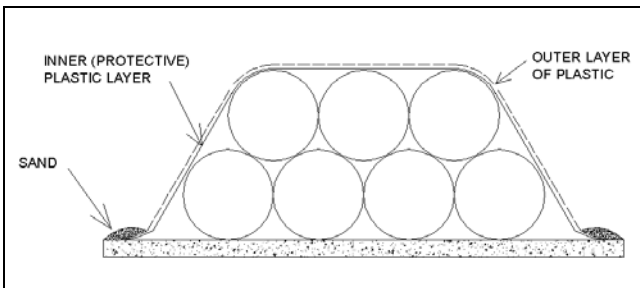

FIGURE 8. Round bale stack face (stacks should be 3–5 bales long)

When stacking round bales (*Figure 8*), do not build stacks more than 2 bales high due to the tendency of these heavy bales to "squat" and become somewhat unstable. In a high stack there is potential for the top bales to shift in any direction possibly breaking the polyethylene seal.

This stacking method works best with square bales (*Figure 9*) as more hay can be fit under the same sheet of plastic. Due to their flat edges, square bales have fewer tendencies to shift and settle and are therefore less likely to break the seal of the stack.

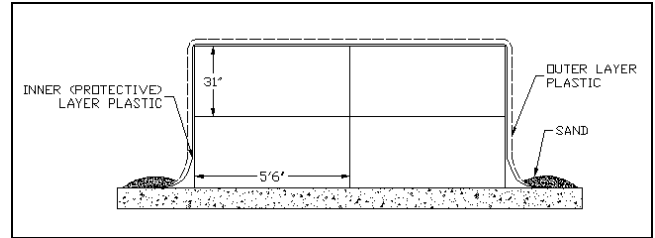

FIGURE 9. Big square bale stack face (stacks should be 5–10 bales long)

For any haylage system, air holes will cause extensive spoilage and if undetected may render the bale a complete waste. Avoid rodent damage by eliminating long grass around the storage site.. Keep in mind that even a pinhole allows enough air exchange for spoilage to occur.

MOULDS

A farmer considering large bale haylage must accept that moulds are a fact of life. Even under ideal circumstances, a small percentage of bales will exhibit some white mould. A bale that has been exposed to oxygen for an extended period will exhibit severe black mould throughout much of the bale. The white mould shown on the end of the bale in *Figure 10* may be the result of the bag being inadequately tied.



FIGURE 10. White mould on a round bale haylage

While no known research has looked at the effects of mouldy material on ruminants, farmer experience has not found it to be a problem (except for feed refusal with black moulded bales). However, the effort to minimize mould in big bale haylage should be the farmer's primary goal.

ECONOMICS

In considering the costs of storing big bale haylage, one must recognize the two-fold economic benefit provided by any of the storage options previously mentioned:

- The plastic enclosures act as the storage facility that would have to be provided for either dry hay or haylage in any forage system.

- The farmer is able to bring the maximum amount of dry matter from the field. Haylage typically will have higher protein levels than dry hay.

If these two benefits are compared to a big bale system for dry hay in which the bales are stored outside, their combined effect would result in 25%-30% more dry matter being available for feeding. At a market value of \$60 per ton of dry hay, this would amount to more than a \$15 per ton benefit. (Note that this comparison deals with the weight of usable product, and does not take into account the higher quality feed available compared to a dry hay system.)

Based on the above, the cost per ton values shown in *Figure 11* and *Figure 12* suggest that storage costs for big bale silage are not unreasonable.

LABOUR

In evaluating any of the large bale haylage storage options, one must consider the labour component. This component should be evaluated not only for harvest and storage, but also for any subsequent handling and feeding operations. With most big bale haylage systems, the farmer is substituting labour for the mechanization available in alternative forage systems.

CONCLUSION

Large bale haylage can provide an economical, quality forage product - especially for farmers who already own round balers or frequently use custom operators or for those who are not large enough to justify the expense of a conventional haylage system.

There are many different big bale haylage options that are best suited to different operations. When looking at the economics involved, there are advantages to each type of haylage system. For example, individual wrapped bales can be more easily marketed off farm. Multi-bale systems use less plastic and are faster to operate, thus lowering operating costs. Stack haylage is a low cost, high management alternative. Depending on the individual farm, one system or a combination of systems may be the superior choice. However, for the beginner, it may be advisable to start small while "learning the ropes". That way, any initial mistakes will not be large ones. For most farms, big bale haylage is at least worth looking into.

This Factsheet was written by **Steven Clarke, P. Eng**, Rural Environment, Field Crop Structures and Equipment Specialist, Kemptville, OMAFRA, and reviewed by **Harold Cuthbertson**, P. Eng., OMAFRA and **Harold House**, P. Eng., OMAFRA.

Agricultural Information Contact Centre
1-877-424-1300
ag.info@omafra.gov.on.ca

www.gov.on.ca/omafra

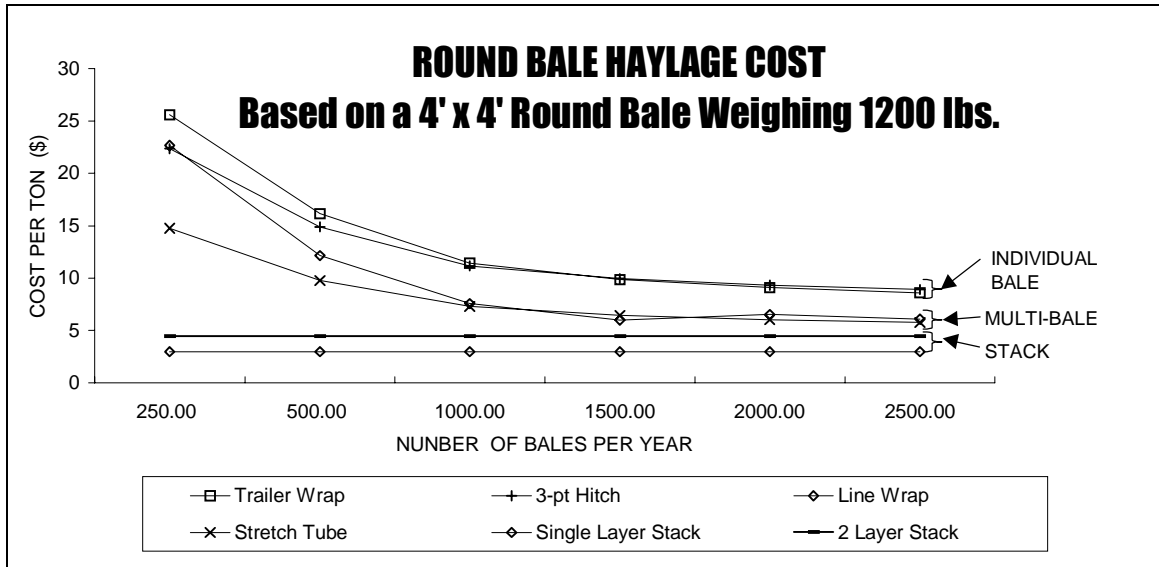

FIGURE 11. Cost per ton comparison of different round bale storage options

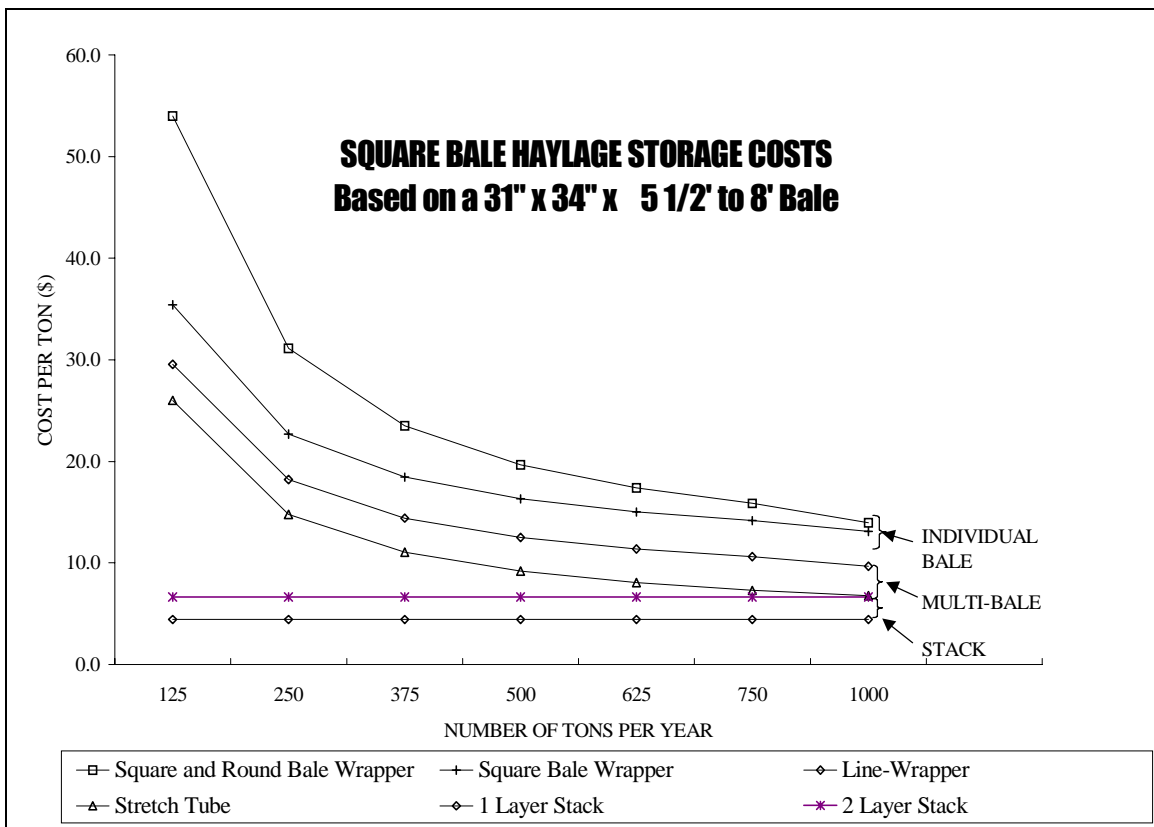

FIGURE 12. Cost per ton comparison of different square bale storage options

FOR YOUR NOTES

POD
ISSN 1198-712X
Également disponible en français
(commande n° 01-074)

